

**Operating an Installation Instructions**

**Magnetic Valve Control**  
with remote ON/OFF input

**MV-05E**  
**MV-10E**

**1 Description .....2**

**2 Frontal View .....2**

**3 Function.....3**

**4 Installation.....4**

4.1 Cabling .....4

4.2 Connection Plan .....5

**5 First Use and Configuration .....6**

**6 Technical Data.....7**

6.1 MV-05E, MV-10E.....7

6.2 Connectable Magnetic Valves .....8

**7 Warning Notices.....8**

7.1 Danger of the Devices .....8

7.2 Permitted Users .....8

7.3 Intended Use .....8

7.4 Electrical Connections .....9

7.5 Installation .....9

7.6 Maintenance .....9

# 1 Description

The magnetic valve controller MV-10E or MV-05E controls and monitors up to 5 or 10 magnetic valves. The connected valves (230V<sub>AC</sub>) are monitored for wire or coil breakage. They are protected in the device with fuses. Unused channels can be deactivated.

The magnetic valves are switched ON and OFF together with a key switch on the device. There is an "Emergency Stop" input to connect a potential-free switch, which forces an emergency shutdown of all magnetic valves.

After a supply voltage failure or an emergency shutdown, the automatic restart is avoided by the controller. To turn the magnetic valves back to ON, the key switch must first be turned to the OFF position and then back to the ON position again.

Magnetic valve faults or an emergency shutdown are indicated acoustically, by an internal piezo buzzer, and optically, by the flashing green LED assigned to the corresponding channel, as well as by two red LEDs for "Fail" and "Emergency Stop".

The "Fail" and "Emergency Stop" messages can be forwarded to a higher-level central control system or to a local "Alarm" through the potential-free contacts of two relays.

Messages can be confirmed with the built-in acknowledgment button. The acoustic message is then switched OFF. If there are no longer any message, the fault message also becomes inactive.

The here described version "E" of the magnetic valve control has an additional input to permit switching the magnetic valves remotely using an external potential-free switching contact. It resembles the internal function when the internal switch is turned ON.

## 2 Frontal View

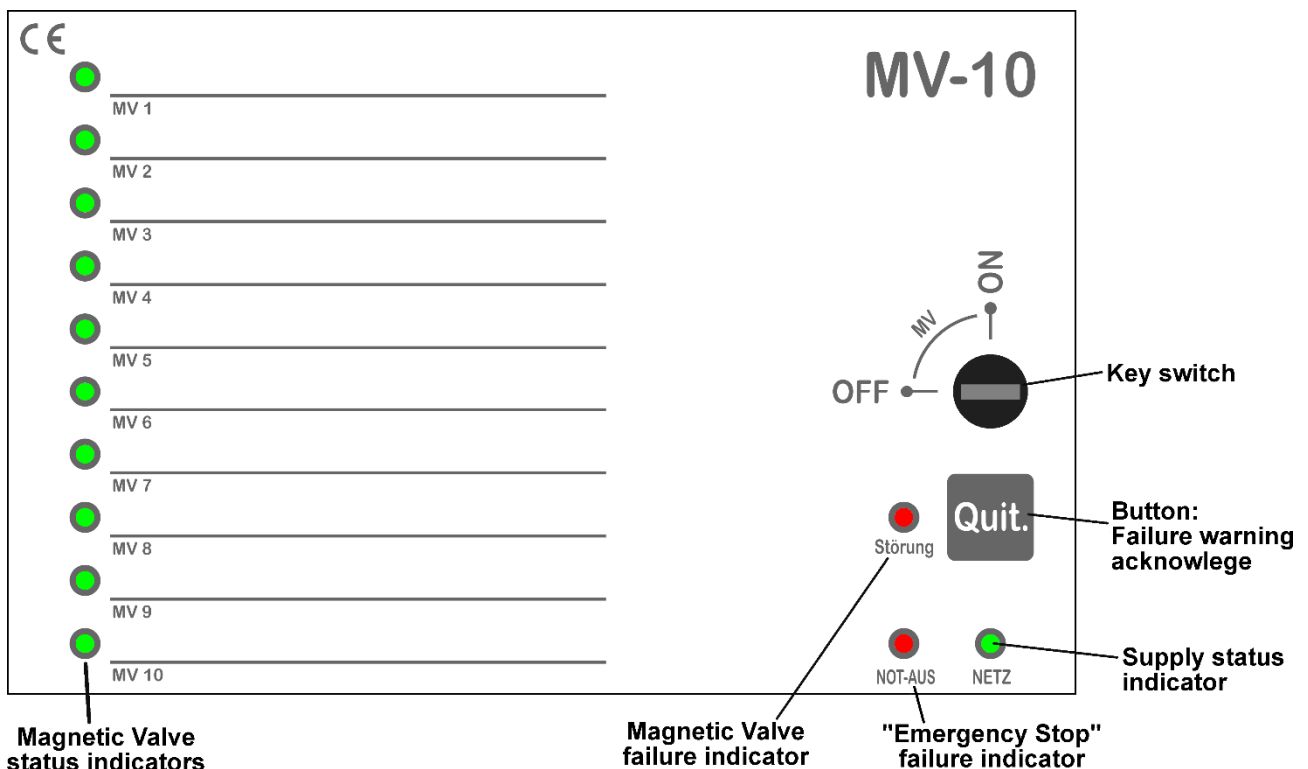

## 3 Function

### Normal Conditions

- The green LED lights up indicating correct supply voltage.
- All red LEDs of the device are **OFF**.
- The key switch stay at **ON** position.
- All activated MV green LEDs light-up.
- The relays "Fail" and "Emergency Stop" are ON (contacts S and NO connected) → the "Fail" warnings are not active.

### Magnetic Valve failure occurrence

An interruption of the current in the monitored magnetic valve, e.g. due to a wire/fuse/coil break, is reported.

- The green LED indicator of the failed magnetic valve blinks.
- The "Fail" red LED blinks.
- The relay "Fail" is OFF (contacts S and NC are connected) → the warning is active.
- The relay "Emergency Stop" remains switched **ON** (S and NO are connected) → the message is not active.
- The internal piezo buzzer reports the valve error acoustically.  
The acoustic message can be stopped by pressing the Quit. button.

### Magnetic valve failure is fixed

- The fixed channel green LED lights-up continuously.
- If no other failed channel, the red LED "Fail" turns OFF
- If no other failed channel, the relay "Fail" turns ON (S and NO are connected) → the message is not active.
- The "Emergency Stop" relay is switched ON (S and NO are connected) → the message is not active.

### Pressing "Emergency Stop" when the magnetic valves are switched ON

The supply voltage for the magnetic valves is done through the "Emergency Stop" switch and channel relays. If the switch is actuated, the supply voltage is interrupted for all valves and they stop working. This situation is recognized by the device as an "Emergency Stop" situation.

- The "Emergency Stop" LED blinks.
- The green supply status indicator LED blinks, indicating that the key switch is still **ON** after a power failure.
- All green MV LEDs are **OFF**.
- The "Emergency Stop" relay is switched **OFF** (S and NC are connected) → the message is active.
- The internal piezo buzzer indicates the emergency condition. The acoustic message can be stopped by pressing the Quit button.

### Unlocking "Emergency Stop" after shutting down the magnetic valves

When the "Emergency Stop" switch is unlocked, the supply voltage on the magnetic valves is not automatically restored.

Only after turning the "key switch" **OFF** and **ON** again, the voltage is restored and the valves go back to **ON**. The green LED "Power" changes to continuously **ON**.

### The "Emergency Stop" button is pressed when the magnetic valves are switched OFF

Pressing the Emergency Stop button (emergency button locked) puts all magnetic valves out of operation.

- The red "Emergency Stop" LED blinks.
- All green MV LEDs are OFF.
- The internal piezo buzzer beeps indicating the "Emergency Stop" situation. The acoustic message can be stopped by pressing the Quit button.
- The "Emergency Stop" relay is turned OFF (S and NC connected) → the message is active.
- The "Fail" relay is turned ON (S and NO are connected) → the message is not active.

### Remote control of the magnetic valves at input X15

The valves can be switched ON/OFF by a remote potential-free switching contact connected to X15. The remote switch function resembles the internal one when this is turned ON.

## 4 Installation

### 4.1 Cabling

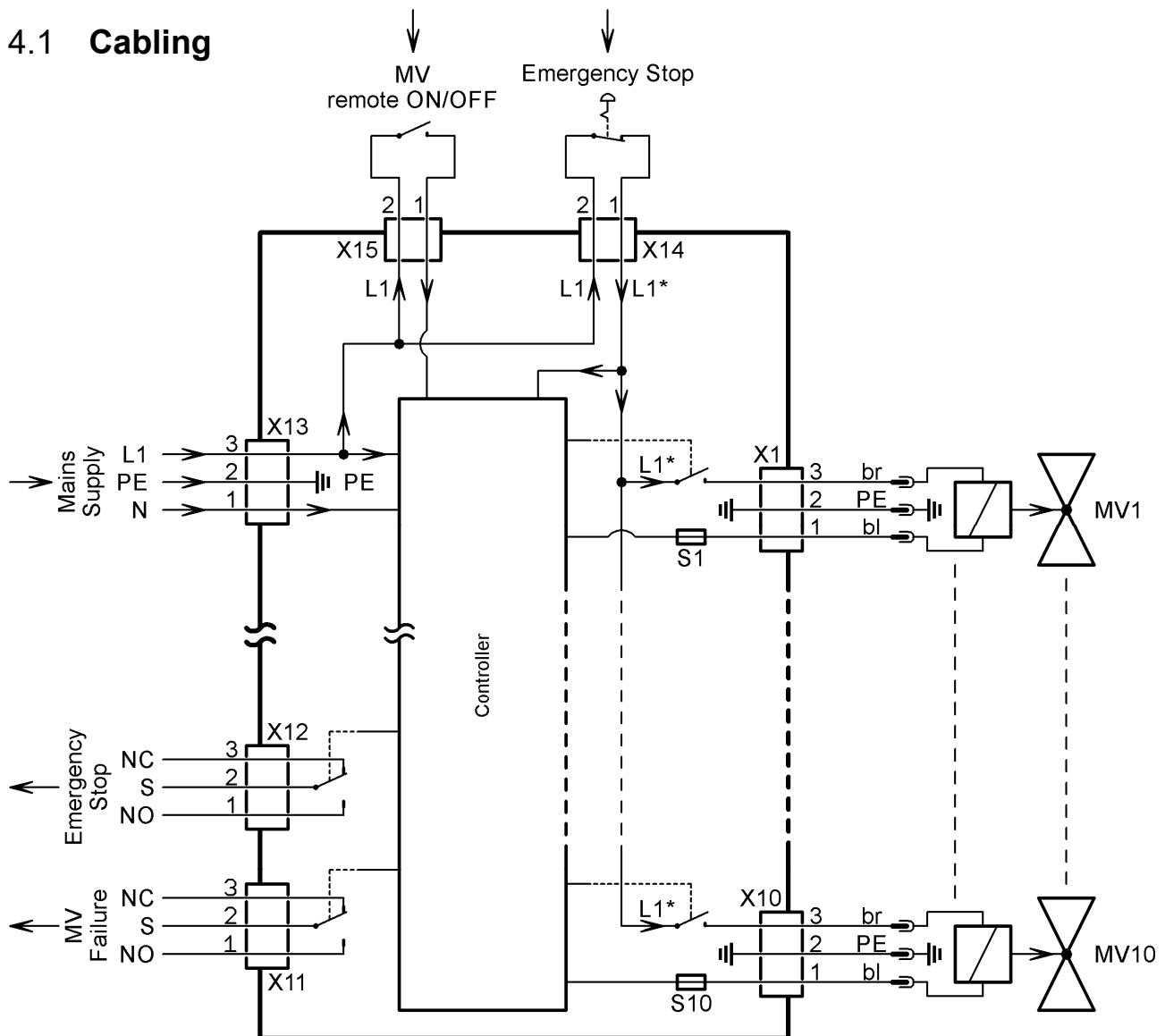

## 4.2 Connection Plan

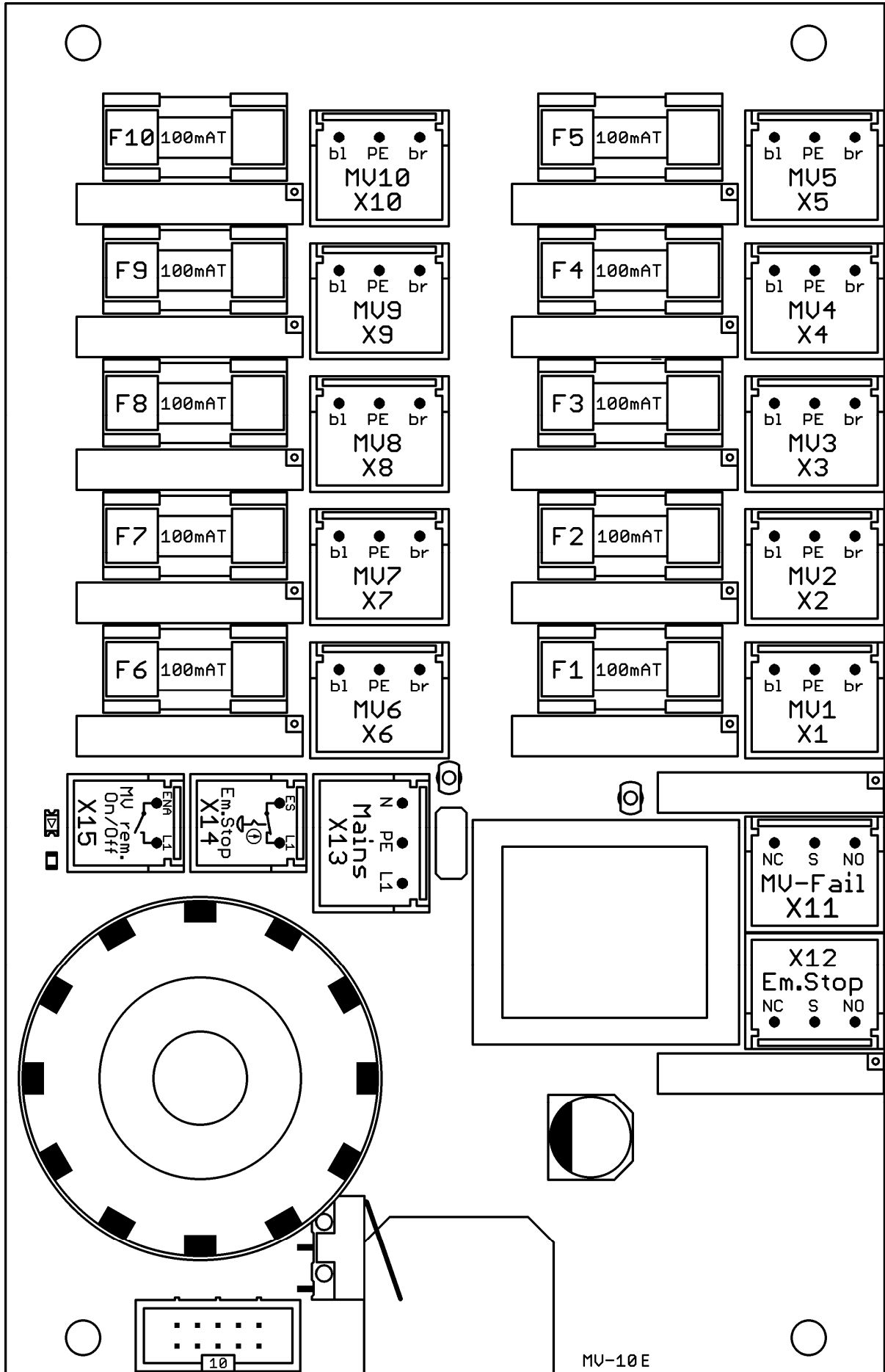

## 5 First Use and Configuration

**! Warning! The MV-5E and MV-10E devices are not suitable for installation in Explosion Zone (Ex. Zone). The device itself must be installed outside of Ex. Zone!**

X1 – X10: MV Channels – connections for the magnetic valves.

X11: Fail – it can be forwarded to a ZTL or connected to an alarm lamp/horn.

X12: Emergency Stop Output – this signal can be forwarded to outside devices.

X13: Supply Voltage (230V<sub>AC</sub>, 50Hz) – power for the device.

X14: Emergency Stop Input – connection of emergency stop button.

**!** X14 is intended for the direct connection of a **potential-free emergency stop button** and already supplies the necessary operating voltage (230V<sub>AC</sub>, 50Hz).

**No external voltage may be applied to X14!**

X15: Remote Switch Connection: A potential-free contact switch is connected to remotely control the magnetic valves. Its function resembles the internal one when this is turned ON (contacts closed and internal control red LED is ON).

**!** X15 is intended for the direct connection of a potential-free switching contact and already supplies the necessary operating voltage (230V<sub>AC</sub>, 50Hz).

**No external voltage may be applied to X15!**

**Before starting the device (key switch in the "OFF" position), unused channels should be deactivated (factory delivered with all channels activated).**

Channels can be **activated/deactivated** as follows:

1. Turn the key switch to the "OFF" position.

2. **Switch ON to programming mode:**

- Hold down the Quit button for approx. 4 s until two short beeps can be heard from the internal buzzer.
- Then immediately press the Quit button twice successively.

3. The green LED of MV1 now flashes every second with a long or short light pulse, depending on the previous channel configuration (active / inactive).

MV1 is then selected for **activation/deactivation**. It can be changed by pressing and holding the **QUIT** button (approx. 1 s). The flashing duration of LED MV1 then changes:

- long pulse → The channel is activated
- Short pulse → The channel is deactivated

4. The next channel for configuration is selected by briefly pressing the Quit. button.

5. **Leaving the programming mode:**

Press the Quit. button for approx. 4 s until first a beep (at 1s) and then two short beeps (at 4s) can be heard from the internal buzzer. The device switches back to normal operating mode.

**Behavior of magnetic valves on non-activated channels:**

When the magnetic valves are switched ON, the operating voltage is only applied to the activated channels. It means that valves on inactive channels are always OFF.

## 6 Technical Data

### 6.1 MV-05E, MV-10E

Parameter	Sym.	Conditions	min	typ	max	Unit
<b>Operating Voltage</b>	$U_V$	X13 50/60 Hz	207	230	240	$V_{AC}$
<b>Power Consumption<sup>#</sup></b>	$P_V$	$207V_{AC} \leq U_V \leq 240V_{AC}$ , without MVs			3	VA
<b>Relay-Outputs</b> X11 MV-Failure X12 Emergency Stop Alert		X11, X12: Changeover contact, potential free, ohmic load	Rated vol- AC	230	250	$V_{AC}$
			tage DC	24	125	$V_{DC}$
			Rated current (ext. protected)		6	A
<b>Emergency Stop Switching</b>		X14 Connector for a <b>potential free</b> connection of Emergency-Stop according to the technical standards.		230		$V_{AC}$
				2,5		A
<b>Remote switch of the magnetic valves</b>		X15 Connector to connect a <b>potential free contact</b> switch according to the technical standards.		230		$V_{AC}$
				50		mA
<b>Conductor cross sections</b>	$\emptyset$	X1...X14 Push-in Cage clamp fine stranded	Without ferrule	0,2	2,5	mm <sup>2</sup>
				24	12	AWG
			With insulated ferrule	0,25	1,5	mm <sup>2</sup>
			With uninsulated ferrule	0,25	2,5	mm <sup>2</sup>
<b>Strip length</b>		X1...X14	9		10	mm
<b>Ambient temperature</b>	$T_F$	in Function	0	+20	+55	°C
	$T_L$	By storage	-20		+60	°C
<b>Case</b>	B	Wide		200		mm
	H	Height		120		mm
	T	Depth		75		mm
		Material	ABS			
		Protection Level	IP65 / DIN 40050			
		Colour	RAL 7035			
		Cable glands	MV-05E	8 x M16		
		MV-10E	13 x M16			

# Plus the power of the magnetic valves → The emergency stop switch must be designed accordingly!

## 6.2 Connectable Magnetic Valves

Each magnetic valve is protected by a fine-wire fuse inside the device.

**! Attention:** When using Ex-magnetic valves, the fine-wire fuses must always be selected in accordance with the data sheet for the valves (see VDE 0165).

Parameter	Conditions	min	typ	max	Unit
Voltage	50/60 Hz		230		V <sub>AC</sub>
Load	Fuse <b>T100mA/250V<sub>AC</sub></b> <sup>1</sup>	MV-05E to serial number FZ <sub>xx</sub> 994 <sup>2</sup>	<b>5</b>	15	VA
		MV-10E to serial number GA <sub>xx</sub> 301 <sup>2</sup>			
	Fuse <b>T200mA/250V<sub>AC</sub></b>	MV-05E from serial number FZ <sub>xx</sub> 995 <sup>3</sup>	<b>3</b>	15	
		MV-10E from serial number GA <sub>xx</sub> 302 <sup>3</sup>			
Fuse <b>T315mA/250V<sub>AC</sub></b>		>15	32	VA	
		>32	50	VA	

<sup>1</sup> factory assembled (5 x 20 mm)

<sup>2</sup> Board "MV-10c"

<sup>3</sup> Board "MV-10d"

## 7 Warning Notices

### 7.1 Danger of the Devices

This monitoring equipment is manufactured and tested in accordance with generally accepted technical standards of the electronics industry.

If used properly, the devices are safe to operate. The units may be operated in a perfect condition and in accordance with the instructions only. Incorrect operation or incorrect commissioning and installation results in

- user life and body hazards,
- damage of devices and other properties of the user,
- device malfunctions.

### 7.2 Permitted Users

All persons involved with installation, commissioning, operation, maintenance and repair of the devices must

- be qualified,
- follow the operating instructions carefully and
- observe the recognized rules for occupational safety.

The devices may be installed and put into operation by trained personnel only. Electrical work must be performed by trained VDE-compliant professional person.

Untrained personnel may work in these products under supervision of trained professionals only.

The operator's manual must be made available for the operator by the system installer.

The installer and the user have to read and understand the manual and this safety information before working with the device.

The minimum age for users is 18 years.

### 7.3 Intended Use

The unit of MV-05E/-10E is exclusively qualified for the monitoring of solenoid valves in normal rooms without potentially explosive areas, so, it may not be installed in environment with risk of explosion.

***The device MV-05E/-10E must be located outside of the explosion prone area!***



In these risk areas, **only explosion-proof pressure gauges and solenoid valves** with a certificate of EC approved test centers for use in Ex-rooms may be used. This certificate does not say anything about the function, but merely indicates that the gauges are explosion protected.

When using the devices, local conditions must be observed. The technical data of the corresponding environmental conditions for the operation of this equipment must be maintained.

## 7.4 Electrical Connections

**WARNING:** Line voltage (230 V<sub>AC</sub>, 50-60 Hz) can cause severe burns. Careless behavior may be dangerous.

Electrical work may be carried out by qualified person only.

The devices may be installed only with disconnected power!

The VDE regulations, accident prevention regulations and operating manuals for the devices must be always observed.

## 7.5 Installation

Before installation, it must be verified that all requirements for trouble-free operation are met:

- Are the MV-05E/-10E and the magnetic valves mounted correctly?
- Is the MV-05E/-10E accessible and visible?
- Are there required environment conditions for installation and operation?
- Are the MV-05E/-10E and the magnetic valves connected properly?
- Is the power supply corresponding to the necessary power ratings?

After installation, the proper functioning of the entire system must be reviewed.

## 7.6 Maintenance

**The devices must be inspected regularly by qualified personnel. The inspection should be documented conclusively.**